

Low Pressure Transmitter (Wetted Part: SUS316L)

VPNPR(G) series

100kPa–1700kPa

100kPa–1700kPa abs



List of digital panel meters

- Diaphragm structure enables high accuracy measurement even in lower pressure range. (Non Linearity: $\pm 0.25\%R.C.$)
- Highly leak-proof and can be used even at high vacuum.
- Gauge pressure reference and absolute pressure reference available.

Measured medium	Water, oil, gases or other media that will not corrode SUS316L.
Pressure Type	Positive, compound, negative and absolute pressures can be measured.
Measured Range	Can be specified within the range of 100 kPa to 1700 kPa of rated capacity (Calibration: 50 kPa to 1700 kPa). Specify more than 50% of rated capacity as the calibration range.
Output type	4–20mA (2 wire system, 4 wire system), Specify among 4 to 20 mA (2-wire, 4-wire), 1 to 5 V, 0 to 5 V, and 0 to 10 V.

Specifications

Non Linearity	$\pm 0.25\%R.C.$
Hysteresis	$\pm 0.25\%R.C.$
Compensated Temperature Range (Temperature of medium to be measured)	0–70°C (No condensation or freezing)

Safe Temperature Range (Temperature of medium to be measured)	-20-80°C (No condensation or freezing)
Temperature Effect on Zero Balance	±1%R.C./0-70°C (At room temperature of 25°C)
Temperature Effect on Load	±1%R.C./0-70°C (At room temperature of 25°C)
Safe Overload Rating	200%R.C.
Ultimate Overload Rating	300%R.C.
Insulation Resistance	100MΩ or more (DC50V)
Pressure Port Material	SUS316L
Connection Screw	Selectable: R3/8 and G3/8
Fastening Torque;Recommended	20N·m
Fastening Torque;Maximum	30N·m
Power	Selectable: 4 DC24V (±10%), 5 DC12V (±10%) *Only 24V DC available when analog output is A5
Cable	44- or 2-core shielded (oilproof) cable 2m(Standard) φ6mm Cable in tube is used for the waterproof connector and pigtail types of output range 500 kPa or below.(Gauge pressure only)
Weight	Approx. 200g (Cable not included)
Accessories	Operating manual 1 copy (Specify English or Japanese.) Test report 1 copy P-20 4D(×1)(G screw only)

Model Selection

	①Model	②Output	③Calibration	④Cable Connection	⑤Power	⑥Length (Cable)
Example	①	-	③	④	-	⑥

Selection	Check	Model	Specifications			
1.Model		VPNPR	Low Pressure Transmitter (Wetted Part: SUS316L) *Connection screw: R3/8			
		VPNPG	Low Pressure Transmitter (Wetted Part: SUS316L) *Connection screw: G3/8			
2.Analog output *Only	-	-	Output type	Response frequency	Safe load resistance	Consumption current
		A2	1-5V	200Hz	5kΩ or more	Approx. 23mA

A6 available for waterproof terminal box type	A3	4–20mA (4-wire)		DC24V: 500Ω or less/ DC12V: 250Ω or less	Approx. 40mA
	A4	0–5V		5kΩ or more	Approx. 23mA
	A5	0–10V		5kΩ or more	Approx. 23mA
	A6	4–20mA (2-wire)		DC24V: 500Ω or less/ DC12V: 150Ω or less	-
3. Calibration	-	-	Rated capacity	Example of calibration range	
	See right table. Enter the range in the <input type="text"/> as it is.	100kPa	<input type="text"/> 100kPa (0–100)kPa	<input type="text"/> ±50kPa (-50–50) kPa	<input type="text"/> 100kPa (abs) (0–100) kPa abs
		200kPa	<input type="text"/> 200kPa (0–200) kPa	<input type="text"/> -100– 200kPa (-100–200) kPa	<input type="text"/> 200kPa (abs) (0–200) kPa abs
		700kPa	<input type="text"/> 700kPa (0–700) kPa	<input type="text"/> -100– 350kPa (-100–350kPa) kPa	<input type="text"/> 700kPa (abs) (0–700) kPa abs
		1700kPa	<input type="text"/> 1700kPa (0–1700) kPa	<input type="text"/> -100– 1000kPa (-100–1000) kPa	<input type="text"/> 1700kPa (abs) (0–1700) kPa abs
4. Cable Connection	N	Standard connector Equivalent to IP40			
	W	Waterproof connector Equivalent to IP56			
	S	Pigtail Equivalent to IP54			
	T	Waterproof terminal box type Equivalent to IP55 *Applicable only when analog output is <input type="text"/> A6. Cable not included			

5.Power		4	DC24 V (±10%)
		5	DC12 V (±10%)*Not available when analog output is A5
6.Length (Cable)		2m	2m Standard
		3m	3m
		5m	5m
		10m	10m
		□□m	Other length *Contact our sales office for other cable lengths.

External dimensions (Unit: mm)

● Standard connector type

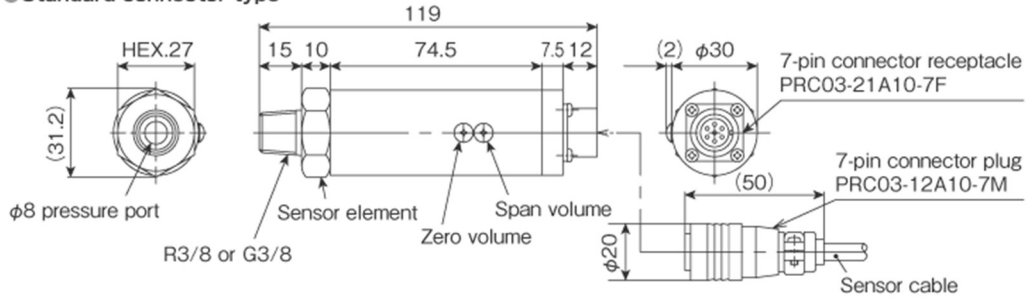

● Pigtail cable type

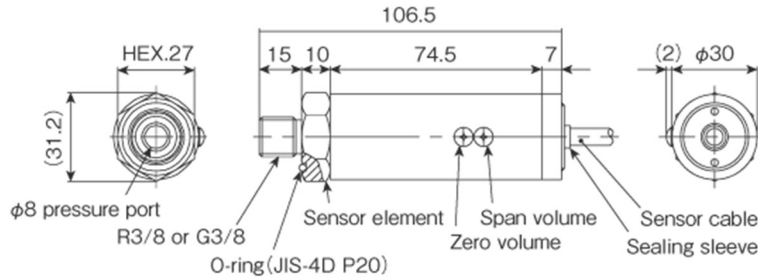

● Waterproof connector type

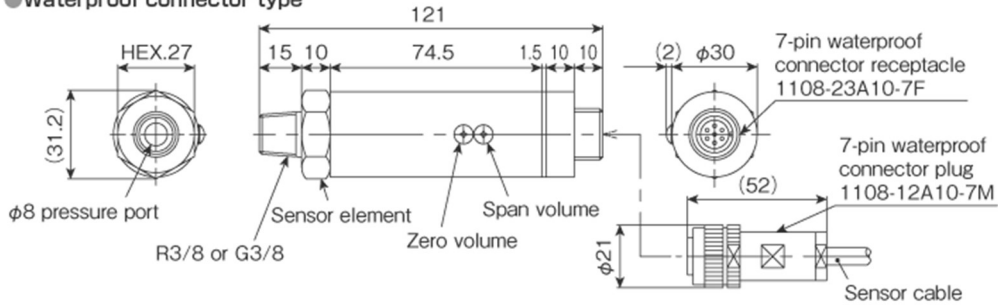

● Waterproof terminal box type

